

Please take time to read and understand these installation instructions.

CORSA recommends that installation of this system be performed by a qualified service center or professional muffler installer who has the necessary equipment, tools and experienced personnel. However, if you decide to perform this install, the use of a hoist and an additional person will be required.

CAUTION: Never work on a hot exhaust system. Allow time for the vehicle to cool. Always wear eye protection when working under a vehicle.

Please confirm that all parts are present before beginning the factory exhaust system removal and CORSA exhaust system installation.

Bill of Materials:

- Driver Side Muffler (13BE2009)
- Passenger Side Muffler (13BE2010)
- Hardware Kit (13BE7011)
- Packet of Anti-Seize

Recommended Tools:

- Safety Glasses
- 15mm socket or wrench
- Saw or chain style pipe cutter
- Grommet Pullers
- Torque wrench
- Soap & water solution

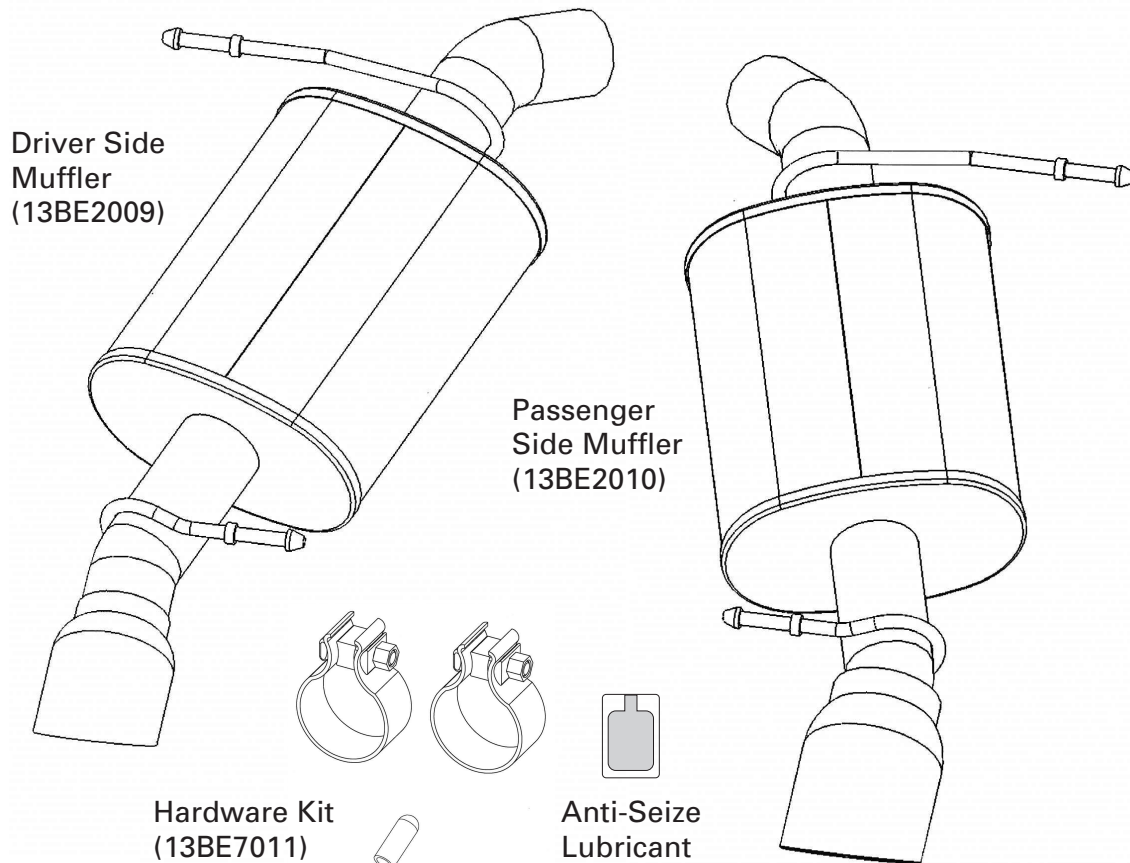

Removal of Stock System:

1. Measure from the inlet weld of the rear muffler and mark 4 inches on the driver side pipe (See Fig. A) and repeat on the passenger side.
2. Using a saw or chain style pipe cutter, cut each pipe at the marks (See Fig. B).
3. Pull the black vacuum line from the driver side muffler, cap the end with the supplied cap, and secure the line in the clip on the heat shield (See Fig. C & D).
4. Remove the rearmost hanger from the driver side rubber isolator (See Fig. E).

NOTE: The use of a soapy water solution may aid in the removal and later installation of the hangers in the rubber isolators.

5. Repeat step 4 for the passenger side, using caution because the stock muffler assembly will rotate down on the remaining two hangers (See Fig. F).
6. Remove the front two hangers to free the stock muffler assembly (See Fig. G & H).

Removal is complete. You may now begin installation of CORSA exhaust system. See page 3.



FIG. A



FIG. B



FIG. C

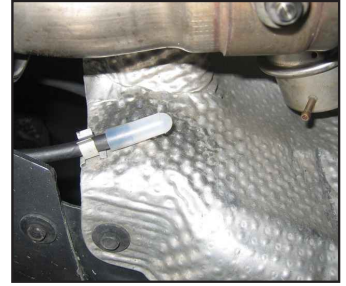

FIG. D



FIG. E



FIG. F



FIG. G



FIG. H

For technical assistance, call **800-486-0999** to speak with a CORSA Representative.

Installation of CORSA Exhaust System:

NOTE: Apply the anti-seize lubricant (supplied) to the threads **ONLY** of all the clamps and flange bolts. Failure to follow this procedure can cause nuts to seize on clamps and potentially destroy threads. After applying anti-seize lubricant, be sure to thoroughly clean hands as lubricant will tarnish stainless steel. All clamps should be tightened using a properly calibrated Torque Wrench. Using an air impact gun will damage the clamp and reduce its ability to effectively seal the joint. It may also cause the joint to separate thereby causing damage to your exhaust system and your vehicle.

1. Remove all exhaust system components from the shipping cartons, including clamps. **NOTE:** There are two 60mm clamps supplied.
2. Locate the passenger side muffler assembly and one 60mm clamp (**See Fig. I**).
3. Align the clamp on the muffler inlet and slide the muffler inlet over the factory pipe (**See Fig. J**). Make sure the muffler inlet is over the stock pipe deep enough that there is no gap shown in the pipe notch. (**See Fig. K**).
4. Insert the hangers into the rubber isolators (**See Fig. L & M**), center the tip in the bumper opening (**See Fig. N**), and using a 15mm socket or wrench snug tighten the clamp (**See Fig. O**).
5. Repeat steps 2-4 for the driver side.
6. Visually inspect the exhaust system position, tip alignment, clamp orientation, and exhaust pipe clearance (**see Fig. P**). Make any necessary adjustment at the slip joint.
7. When the exhaust system is in the desired location, tighten all the TORCA clamps. **NOTE:** Due to the bumper design, check the tip alignment from 10 feet behind the vehicle.
8. It is **STRONGLY SUGGESTED** that all clamps be checked and tightened if necessary after road testing the vehicle once the system has cooled.

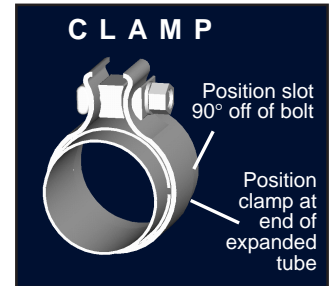

FIG. I



FIG. J

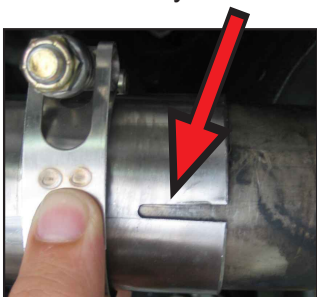

FIG. K

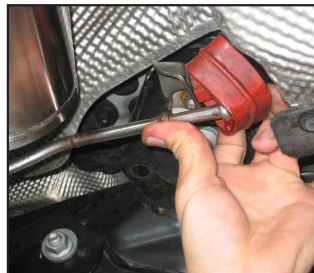

FIG. L



FIG. M



FIG. N



FIG. O



FIG. P