



UUC PART# UDPE46
Installation Guide - Underdrive Accessory Pulleys
for E46 330, 328, 325, 323 models

Professional installation recommended, but not required. Installer is responsible for determining his or her ability to perform this work competently and safely.

Parts included:

- (1) replacement power steering pulley (marked as "1")
- (1) replacement water pump pulley (marked as "2")
- (1) replacement accessory belt (part #K060630).

IMPORTANT: BEFORE BEGINNING INSTALLATION, MAKE SURE THE PARTS YOU HAVE MATCH THE LIST ABOVE.

Tools required: metric socket set, torx set, flat-blade screwdriver or needle-nose pliers.





Step 1: Intake inlet is attached by three push-rivets. Use a flat-blade screwdriver or needle-nose pliers to lift the center portion, and then remove the entire rivet. Retain these pieces for re-use.

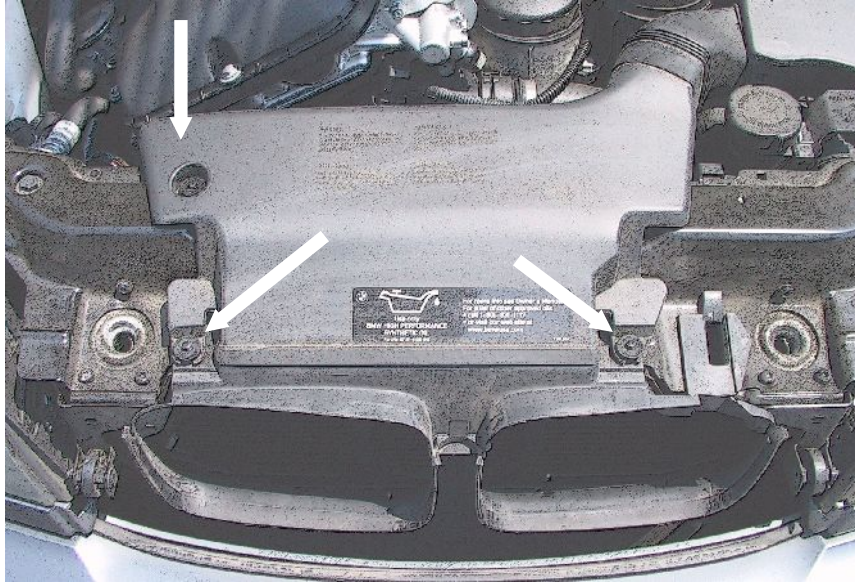

Step 2: Remove intake duct by pulling away from part:

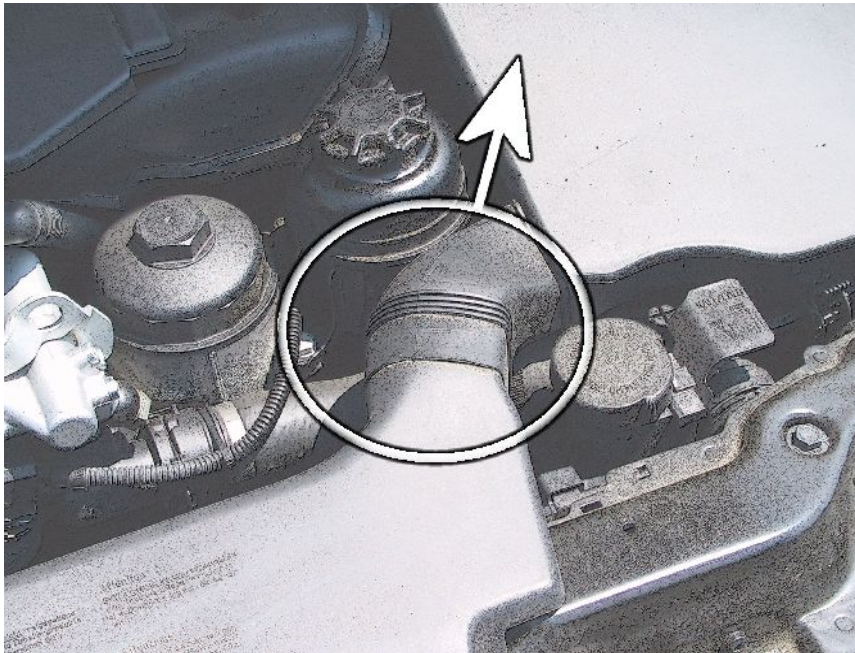

Step 3: Remove intake parts completely and set aside.



(Note: pre-2001 models with clutch fan will follow standard clutch fan removal procedure and ignore steps 4-7.)

Step 4: Fan removal begins by removing this torx bolt located on the right side of vehicle:

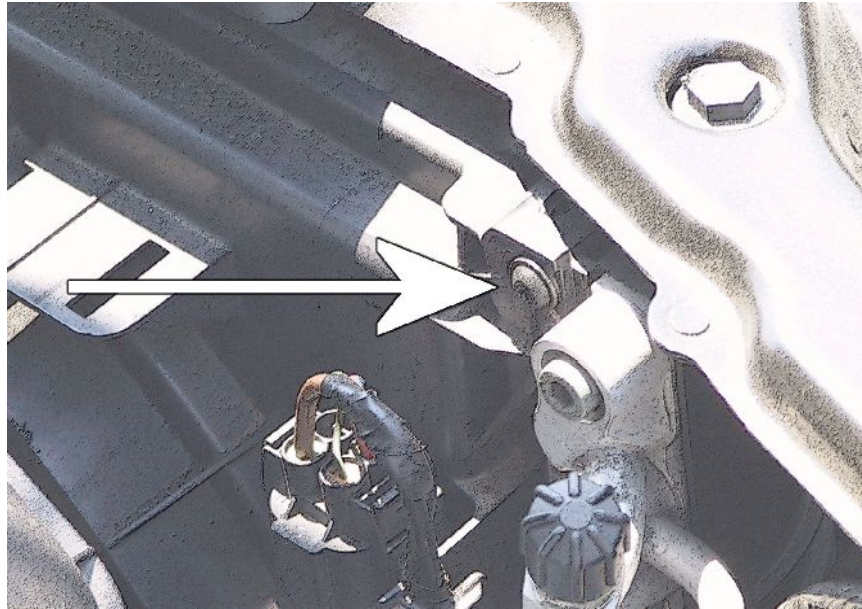

Step 5: Unplug electrical connections:

Style 1

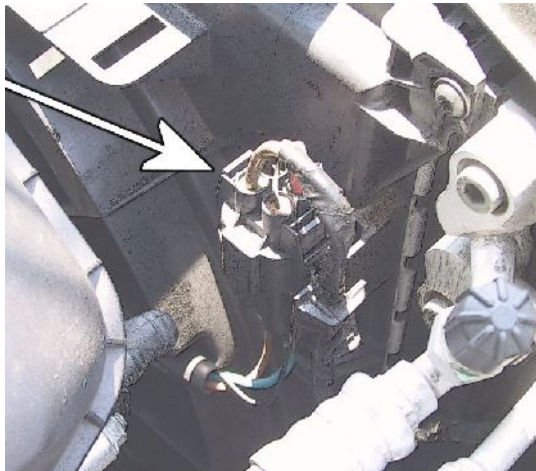

Style 2

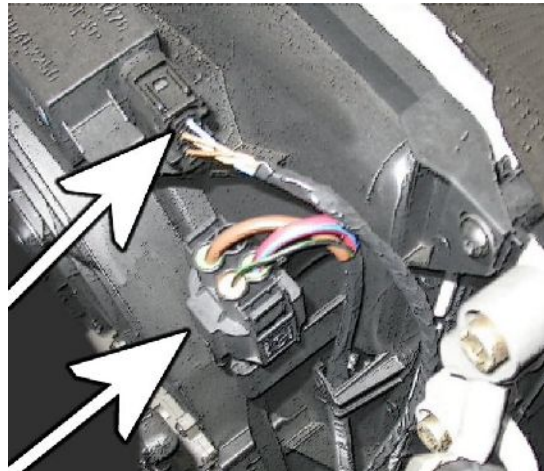



Step 6: Remove push-rievet on left side of car.

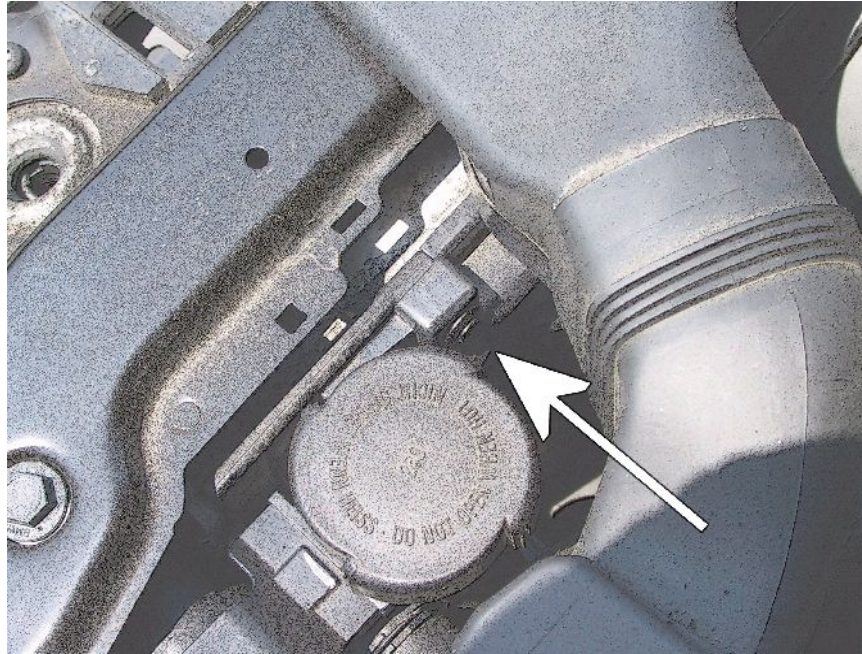

Step 7: Lift fan up and out of car.

Step 8: Use a 10mm socket to loosen the four (4) water pump pulley bolts. **Do not remove completely.**

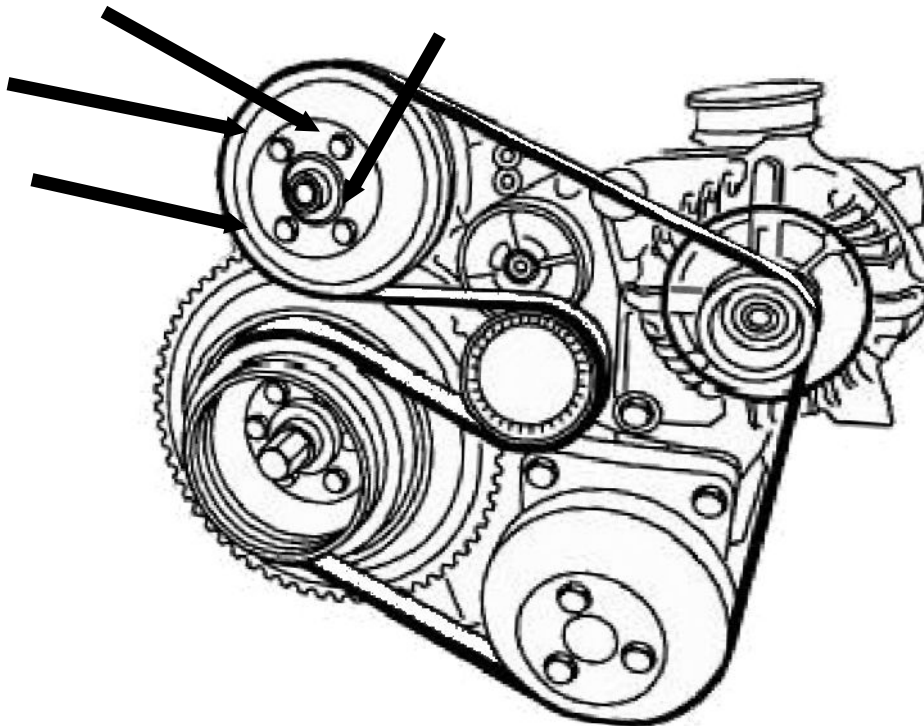



Step 9: Use a 13mm socket to loosen the three (3) power steering pump pulley bolts marked "B". Do not remove completely.

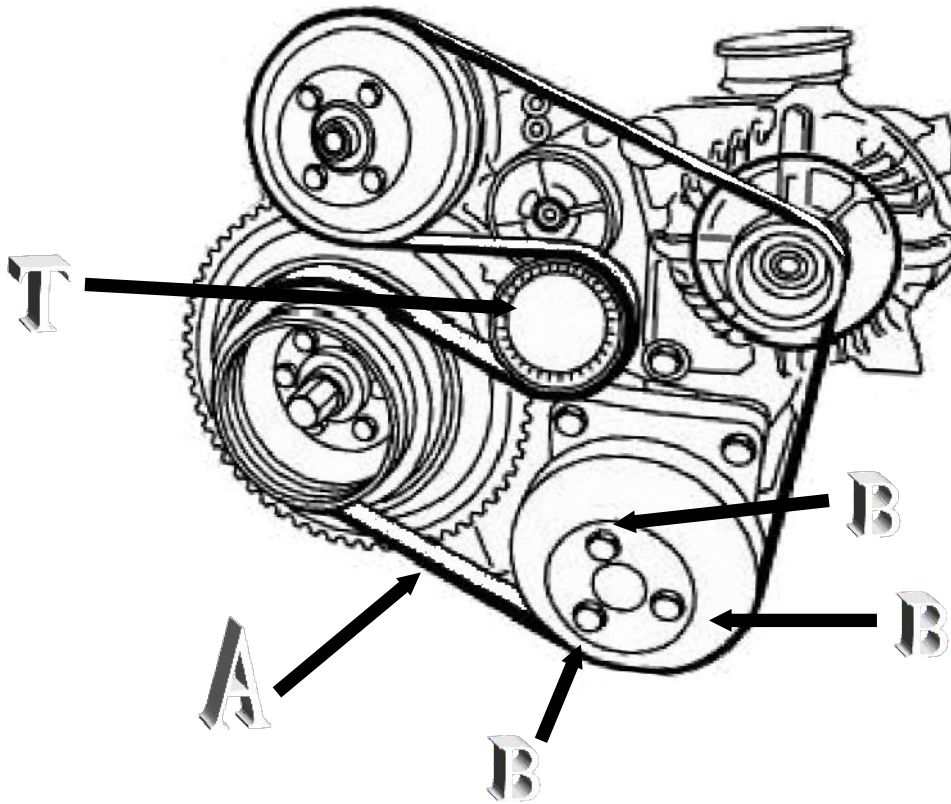

Step 10: Remove cap from tension roller marked "T" and turn exposed belt to relieve tension on belts:

Step 11: Remove auxiliary belt:

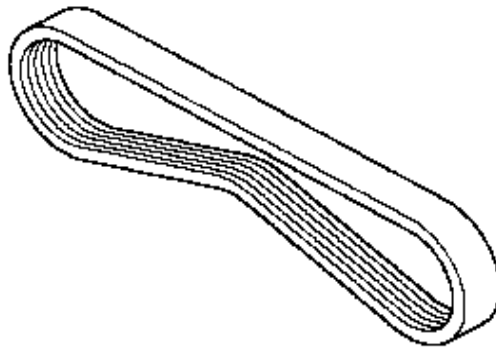

Step 12: Remove main accessory belt marked "A" above.



Step 13: Remove original pulleys completely and replace with UUC pulleys. Fasten using original bolts.
IMPORTANT: accessory pulley bolt torque spec is **16lb-ft**. Do not over-tighten!

Step 14: Install new drive belt and auxiliary belt. Note correct routing path:

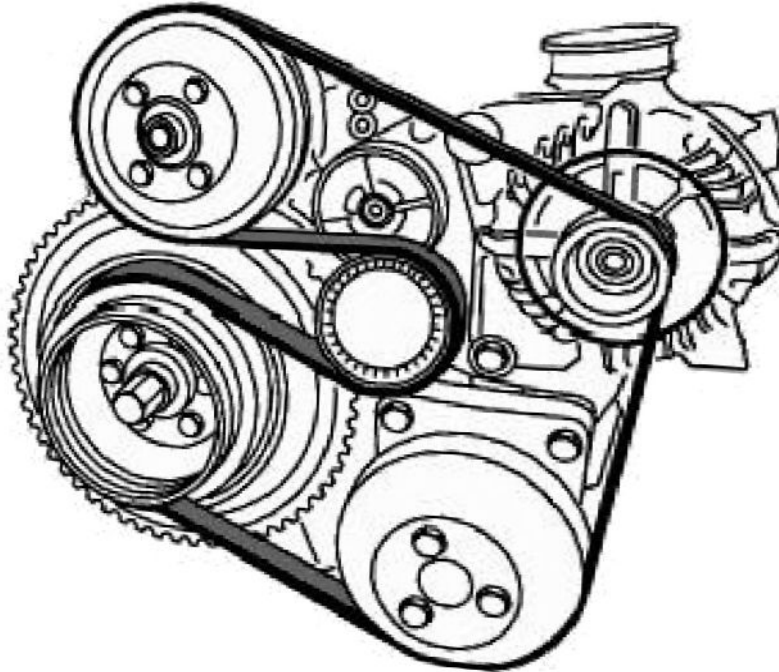

Step 15: Tighten tension roller and replace cap.

Step 16: Re-install fan by following steps 4-6 in reverse order.

Step 17: Test fitment of accessory belt and auxiliary belt by starting car and listening for squealing. Turn a/c on and listen again. If belts make noise or appear too loose, return to step 15.

Step 18: Re-install intake inlet by following steps 1-3 in reverse order. **IMPORTANT:** Turn car off before working again!

Step 19: Drive and enjoy!